

Seperatör Serisi

Firmamız mühendisliğinde imalatını yaptığımız endüstriyel kontrol elekleri ile pnömatik nakil proseslerinde kullanacağınız hammaddelerinizi mıknatıs ve merkezkaç kuvveti ile çalışan santrifüj eleklerde eliyor ve prosesinizi kontrol altına alıyoruz.



Depolama yaparken veya depolamadan sonraki mekanik, pnömatik nakil proseslerinde kullanacağınız hammaddelerinizi mıknatıs ve merkezkaç kuvveti ile çalışan pnömatik eleklerde eliyor ve prosesinize temizlenmiş olarak işleme hazır hale getiriyoruz. Silolara silobas ile mal doldurulurken kullanılan elektipi ile proses çalışırken kullanılan elek tipi(yanda) birbirinden farklı yapıdadır. Eleklerimiz özellikle gıda ve kimya proseslerinde sıklıkla kullanılan cinstendir. Elek kapasitesi elek delik aralığı ile direkt olarak orantılıdır. 550mikrona kadar eleme kapasitesine sahip olan eleklerimiz, prosesin durumuna göre istenilen delik çapına göre revize edilebilir. Bunun yanında bu tür eleklerin en büyük problemi olan elek telinin patlama,yırtılma riski konstrüksiyonundan dolayı söz konusu değildir.

We also apply vibration and conical pneumatic screening technologies in your pneumatic transfer processes and silobuses. Thanks to the conical screens in the range of our products which are installed at the highest level of the silos, we prevent ingress of foreign objects into your silos. Foreign materials especially sand, calcite and similar materials in the construction chemicals may give damage to the screws and mixers, other transport equipment of the process. For this reason, the raw material introduced in the process should be screened definitely

Companies in the food, feed, pharma and chemical industries are being confronted with increasingly stringent requirements with regard to food safety, quality, tracking & tracing and hazards associated with dust and explosion. So it should come as no surprise that DOSERAY Process Technology is continually searching for the best solutions when it comes to quickly and reliably managing various granulated as well as powdered materials. Efficient fractionation ensures the highest purity Our sieving technique is based on the use of our centrifugal sieves.

SIEVE TECHNOLOGY

Dry or moist bulk solid material is gravity-fed into the feed inlet and redirected into the cylindrical sifting chamber by means of a feed screw. Rotating helical paddles within the chamber continuously propel the material against the screen, while the resultant, centrifugal force on the particles accelerates them through the apertures. On-size particles are funneled through a discharge housing equipped with an inspection door, while oversized particles and trash are propelled through the screen cylinder and ejected through a discharge spout. In addition to sifting and scalping of dry bulk materials, the screener can break up soft agglomerates and/or dewater moist solids or slurries.

The material to be fractionated is brought into the sieving chamber, where the material is agitated by spinning fins. Those fractions which consist of small enough particles pass through the centrifugal sieve, whereas contaminants and larger particles are quickly transported onwards. By varying the rotation speed as well as the diameter of the openings and the path length of the sieve, we can realize any desired sieving result. And our broad range of accessories and options makes it possible to realize the necessary level of quality, safety and hygiene for any situation.

HYGENIC DESIGN SIEVE

The machine housing and the screens are completely made of stainless steel. A new tangential inlet without screws prevents product from accumulating in the inlet. This makes the inline check sieve the perfect choice for use in the finished product section.

Genellikle pnömatik un transfer sistemlerinde son kontrol eleği olarak kullanılan santrifüj seperatör için 1000-2000 micron ürün geçecek

Ürün Teknik Özellikleri:

- 1.5kw 1400 rpm,50Hz,3phase Motor
- Direkt akupile tahrik sistemi
- Kolay açılıp kapanır contalı sızdırmaz kapak
- 1000micron tel ile 5m3/saat un eleme
- Max Çalışma Basıncı:1bar
- Boru giriş-çıkış: Opsiyonel (76.1mm,88.9,101mm)

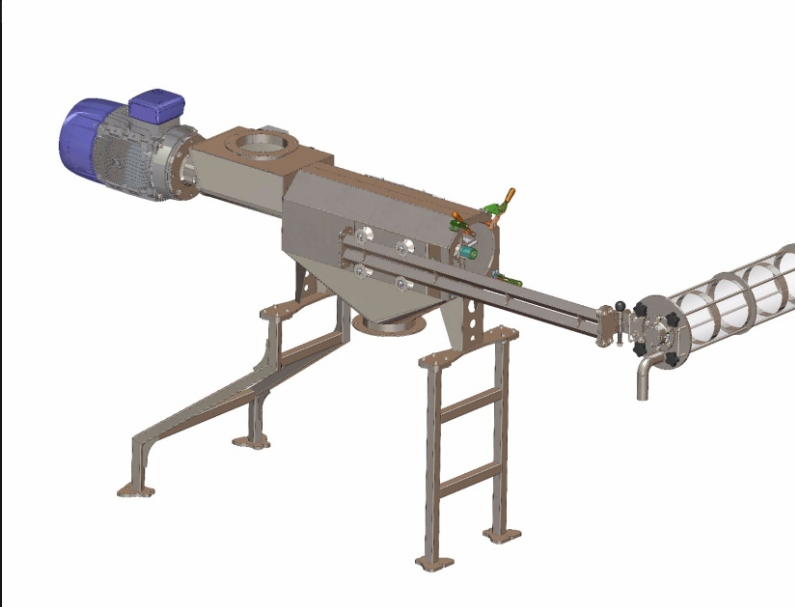

SIFTING PRINCIPLE OF OPERATION

Material is fed into the feed inlet and redirected into the cylindrical sifting chamber by means of a feed screw. Rotating, helical paddles within the chamber continuously propel the material against the screen, while the resultant, centrifugal force on the particles accelerates them through the apertures. These rotating paddles, which never make contact with the screen, also serve to breakup soft agglomerates. Over-sized particles and trash are ejected via the oversize discharge spout.

Transport capacity: 3-6 to/h

Length:1600mm Width:1700mm Height: 1500mm

Construction material: stainless steel

screen: different mesh sizes from 0,6 to 3mm

Debris unloading: automatically with electropneumatic shut-off valves

Pipe connections: 60 - 114mm diameter

Operation type: vacuum or pressure

Drive: 3kW

DOSERAY
DEPOLAMA - DOZAJ - PROSES

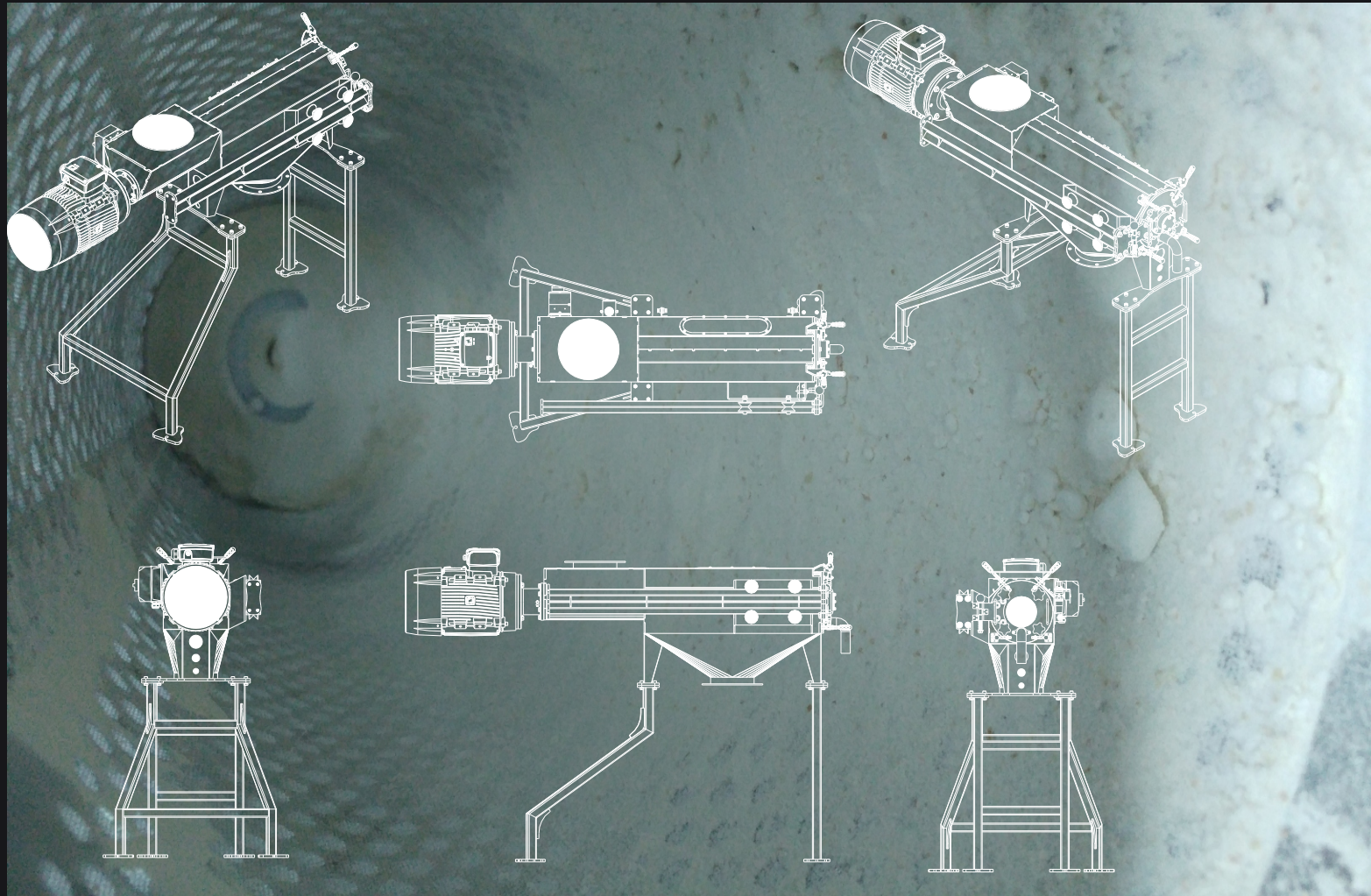

**SULTAN
MAKINA**